

UN002223-DU

## PART KITS / 配套零件

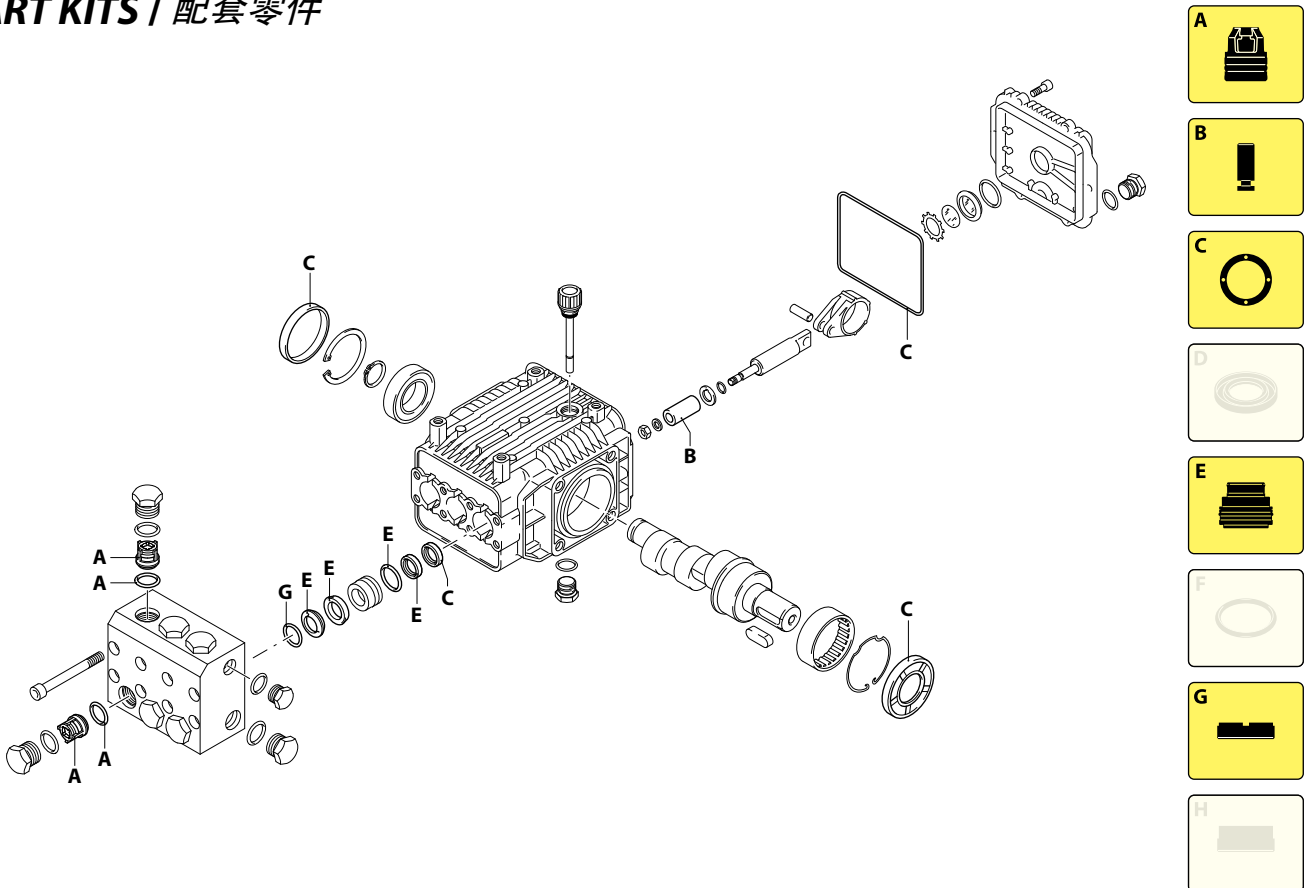

UN002224-DU

# 258 Series

XM-SS 1450 rpm N version ø 24 m

11.17



Pos. 序号	Cod. 编号	Description	描述	Qt 数量	Note 备注	Pos. 序号	Cod. 编号	Description	描述	Qt 数量	Note 备注
1	960160	O-ring	Ø 17,86x2,62	6		72	1260430	Ring	环	1	
2	2580031	Plug		6	☉C=50Nm	73	1780690	Plate	金属片	1	
3	2589050	Complete valve		6		74	1140450	O-ring	Ø 20,24x2,62	1	
4	880830	O-ring	Ø 15,54x2,62	6							
6	1780130	Ring	appoggio Ø15	3							
7	1260130	Water seal	Ø 15	3							
8	1781030	Ring		3							
9	2580010	Pump body		1							
10	1266740	Oil seal		1							
11	1260790	Ring	seeger Øi 52	1							
12	1780550	Ring		1							
13	1780490	Bearing		1							
14	880130	Plug		1							
15	1780050	Pin		3							
16	1780510	O-ring	Ø 106x3	1							
17	680560	Screw	TCEI M6x16	6	C=9Nm						
18	2349010	Cover	completo	1							
19	1780710	Connecting-rod	bronzo	3							
20	1780060	Piston	di guida	3							
21	480480	O-ring	Ø 4,48x1,78	3							
22	2580120	Plate		3							
23	1780070	Piston	Ø 15	3							
24	2340200	Washer		3							
25	2580110	Nut	M8	3	☉C=10Nm						
27	740290	O-ring	Ø 14x1,78	2							
28	2340350	Plug	3/8" G	3	C=20Nm						
30	1260460	Oil seal		3							
31	2580050	Piston guide	Ø 15	3							
32	770260	O-ring	Ø 23,52x1,78	3							
33	1260440	Water seal	Ø 15	3							
34	2340360	Plug	1/2" G	1	C=30Nm						
35	180101	O-ring	Ø 17,5x2	1							
36	2580020	Head		1							
38	2580090	Screw	TCEI M6x60	8	C=9Nm						
39	740290	O-ring	Ø 14x1,78	1							
40	1321190	Bearing		1	(d)						
41	1321080	Ring		1							
45	1780150	Shaft	marcato 1	1							
46	1380520	Key		1							
47	1260750	Oil seal		1	(b)						
57	2589202	Head assembly		1							
71	1260250	Level gauge		1							

## PART KITS - 配套零件

A=KIT 2282 valves 单向阀		B=KIT 2739 pistons 柱塞		C=KIT 2786 oil seals 油封		E=KIT 2283 water seals 水封	
Pos. 序号	Q.ty 数量	Pos. 序号	Q.ty 数量	Pos. 序号	Q.ty 数量	Pos. 序号	Q.ty 数量
3	6	23	3	10	1	7	3
4	6			16	1	8	3
				30	3	32	3
				47	1	33	3

G=KIT 2740 support rings 支撑环							
Pos. 序号	Q.ty 数量	Pos. 序号	Q.ty 数量	Pos. 序号	Q.ty 数量	Pos. 序号	Q.ty 数量
6	3						

## SIMBOLOGIA - 标记



- C Tightening torque tolerance 0±10% / 拧紧力矩公差 0±10%
- ☉ Screw with Loxeal 55-14 / 用 Loxeal 55-14 螺丝
- (b) Fit the seal with tool code nr. 1941990 / 使用工具 nr. 1941990 进行密封
- (d) Fit with special tool code nr. 1780610 / 使用特制工具 nr. 1780610

Oil - 机油			
Type / 类型	Quantity / 数量		
SAE 75W90	0,430 Kg		